

THE SMITH RESIDENCE
RE-MODELING OF A CONDOMINIUM
BAYSHORE BLVD. TAMPA, FL



Lic# ID 0002289
FL# 13 0001146
Kelly@kellytaaffedesign.com
Tel.: 813.695.5049
Fax: 813.805.2371

**ELEVATIONS
A-30**

SCALE: VARIES"

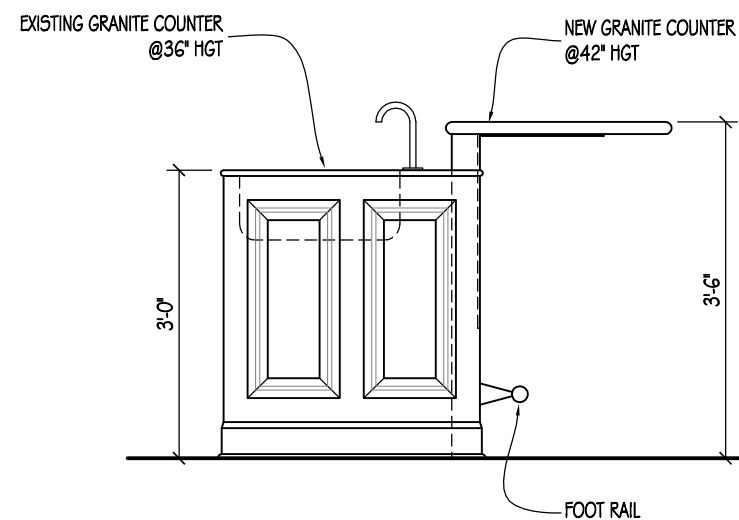

06 - SIDE ELEVATION
1/2" = 1'-0"

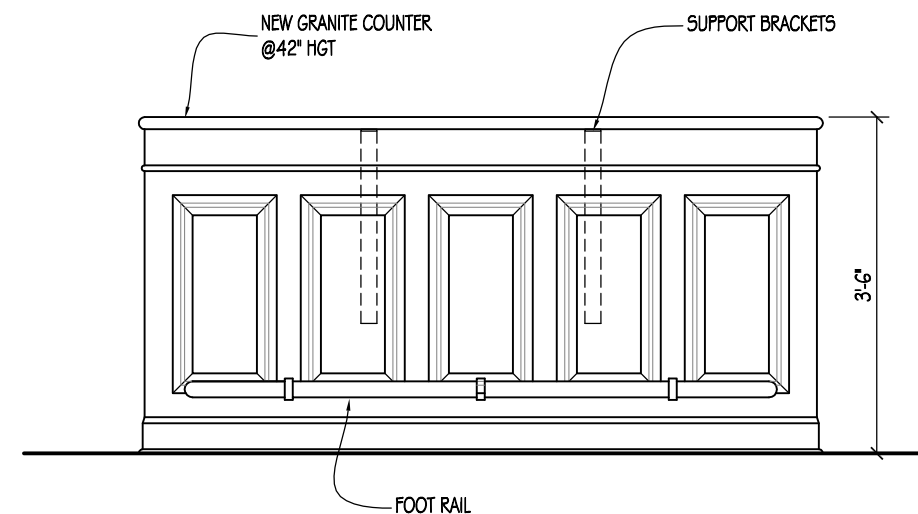

05 - FRONT ELEVATION
1/2" = 1'-0"

NOTES:

- PANEL MATERIAL: STAIN GRADE SOLIDS 3/4"
PINE
ALT. ASH
OAK RED
STAIN SAMPLES MUST BE APPROVED BY DESIGNER
- MODLINGS: SOLIDS TO MATCH
- BASE + CROWN: SOLIDS TO MATCH - DESIGNER TO SELECT FROM STANDARDIZED
MOLDING, CROWN + BASE, NO CUSTOM PROFILES, KNIFES, FOR EDGES.

ALL DIMENSION TO BE VERIFIED IN FIELD

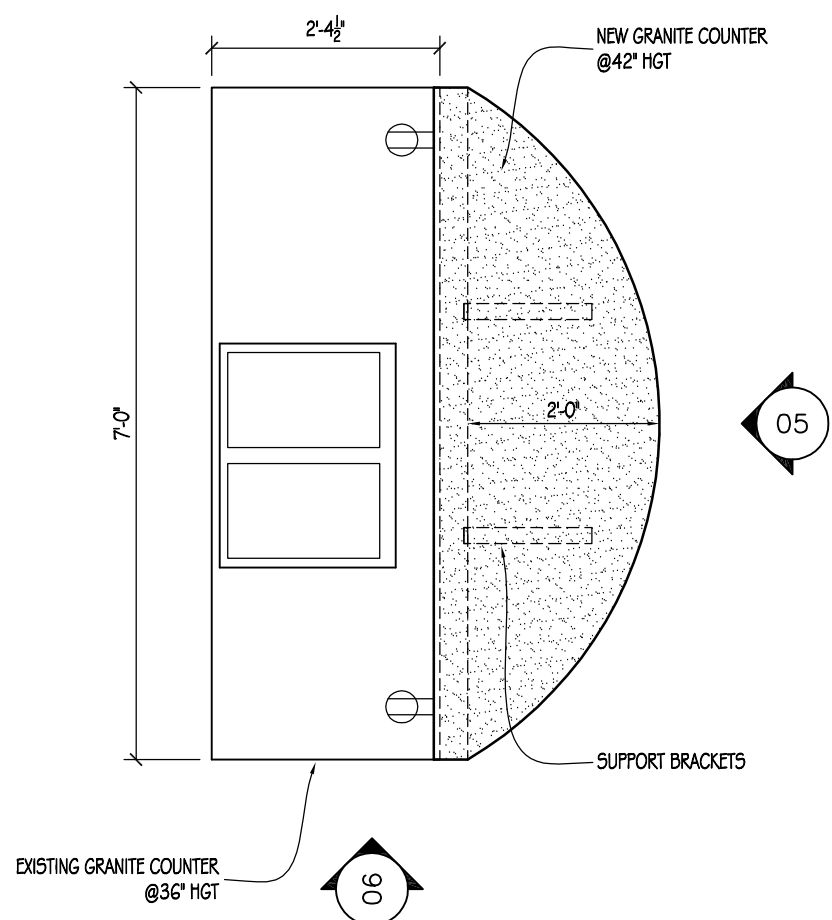

KITCHEN ISLAND
1/2" = 1'-0"

